

Final Design Package
09.26.2007



**New Administrative Building, Parking
Structure, and Domiciliary
Veterans Development, LLC**



400 Western Reserve Bldg.
1468 West 9th Street
Cleveland, Ohio 44113
www.kaczarch.com

216-687-1555
fax 216-687-1558

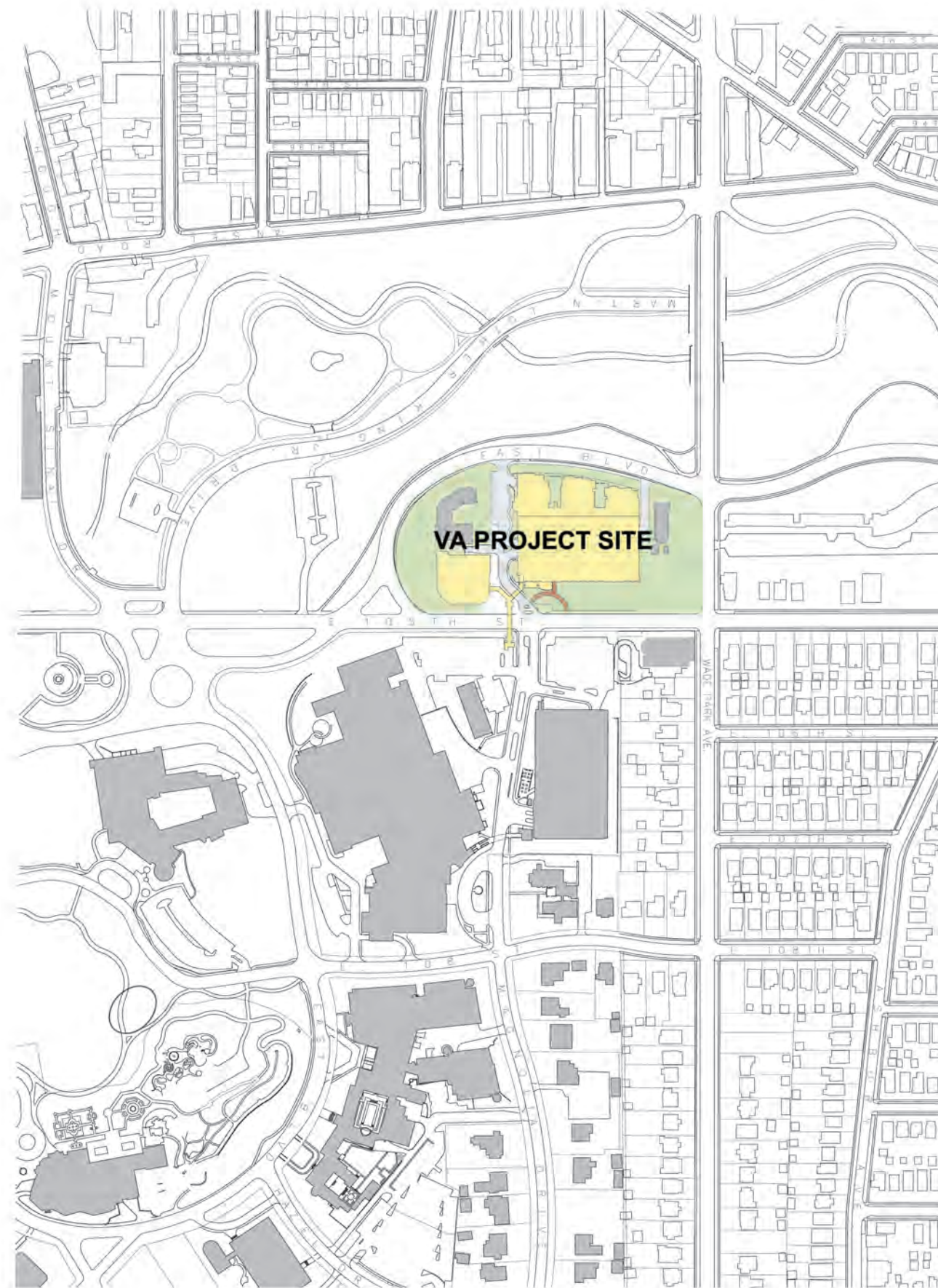

 SITE CONTEXT PLAN
SCALE: 1" = 250'-0"



New Administrative Building, Parking Structure and Domiciliary - Veterans Development, LLC
Aerial Photograph - 09.26.07



Existing Magnolia Building - Veterans Development, LLC
Existing Conditions - 09.26.07

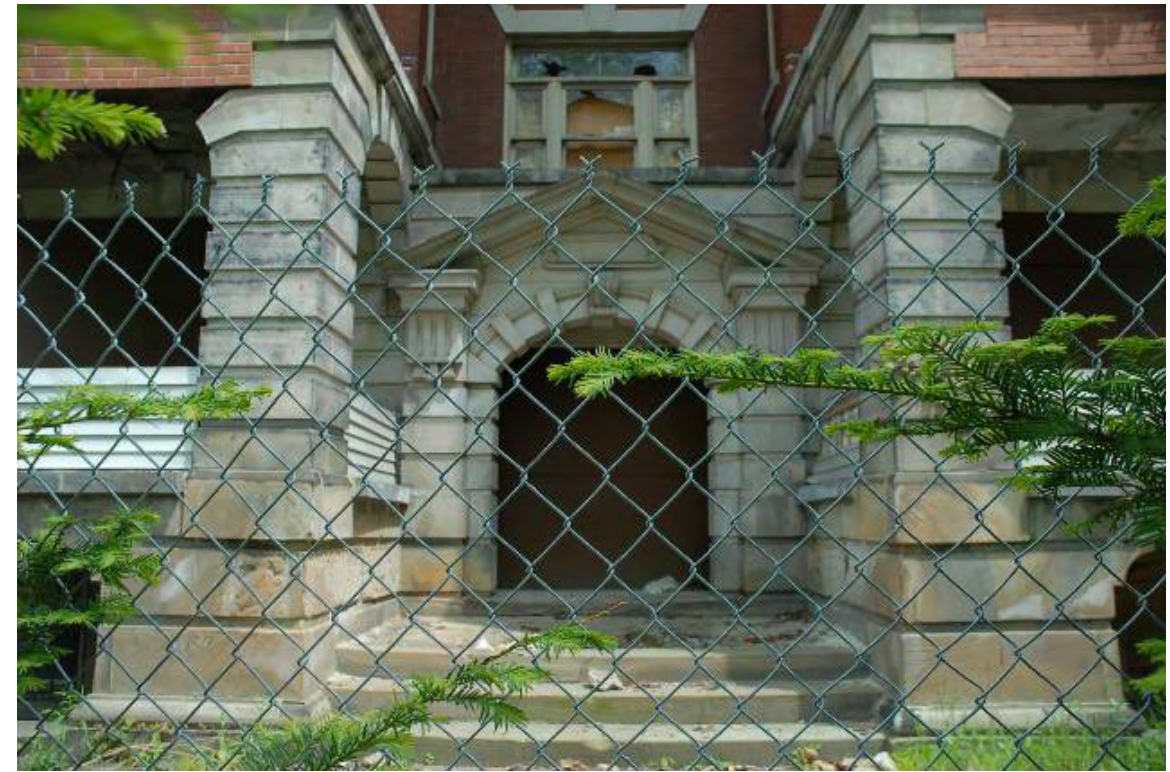

Existing East Boulevard Buildings - Veterans Development, LLC
Existing Conditions - 09.26.07



Existing Marchand Building - Veterans Development, LLC
Existing Conditions - 09.26.07

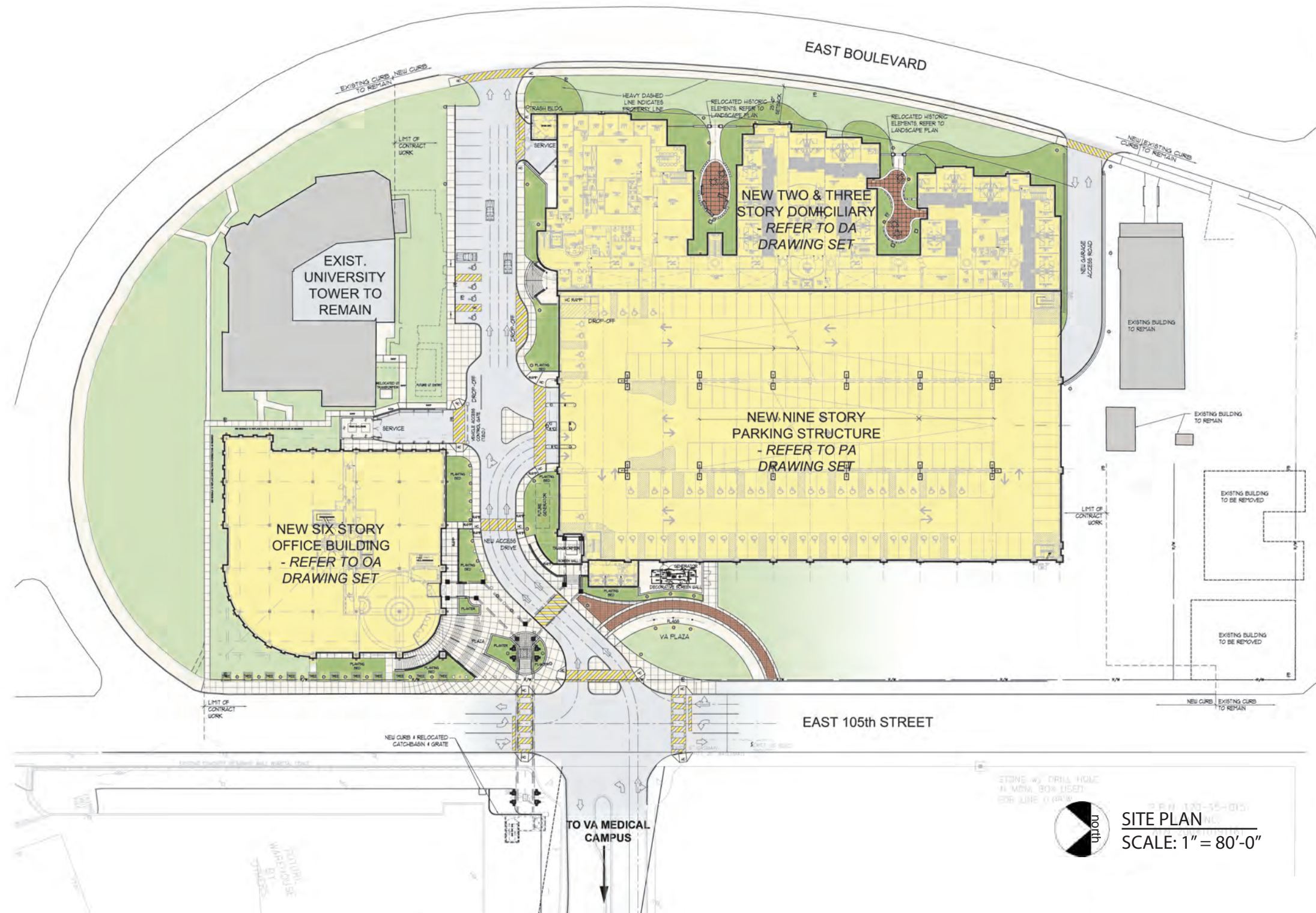

Proposed Overall Site Plan - Veterans Development, LLC
 Grade Level Plan - 09.26.07



McKnight Associates Ltd.
 LANDSCAPE ARCHITECTURE
 812 Huron Road
 Suite 421
 Cleveland, Ohio 44115-1126
 216 771-1800
 216 771-1803 fax
 www.mcknightla.com

Note
 1. CONTRACTOR TO VERIFY CONDITIONS AND DIMENSIONS IN THE FIELD AND NOTIFY THE OWNER OR ARCHITECT OF DISCREPANCIES.
 2. CONTRACTOR IS RESPONSIBLE FOR PROVIDING PLANT QUANTITIES DETAILED ON PLAN. SCHEDULE PROVIDED FOR REFERENCE ONLY.



Ornamental Iron Fence



East Boulevard Apartment Pediment Entry



Salvaged Stone @ Courtyard Planters

STONE w/ DRILL HOLE IN MON. BOX USED FOR LINE 0.08'W



SITE PLAN
 SCALE: 1" = 80'-0"

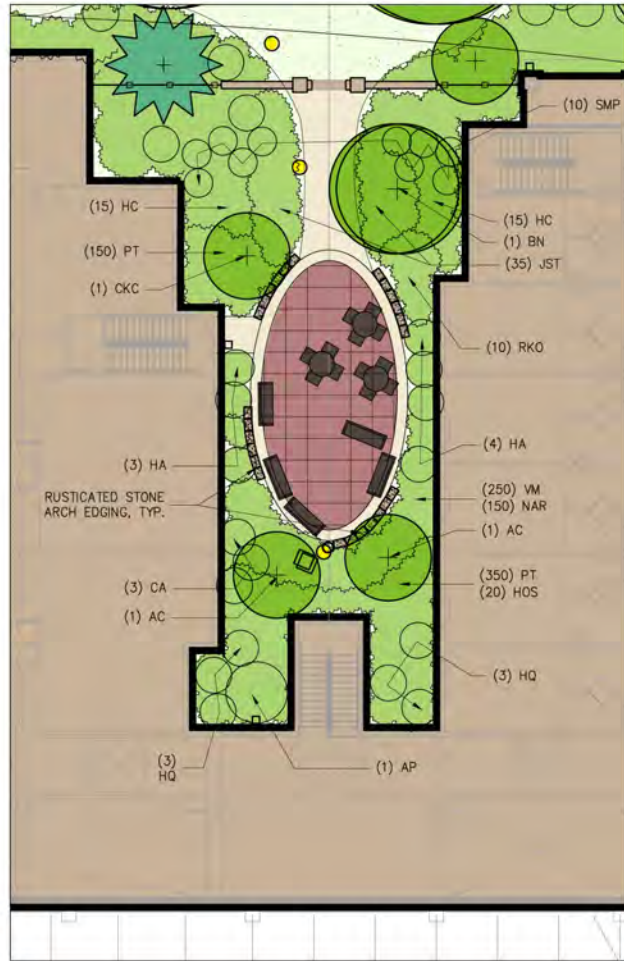

Enlarged South Courtyard

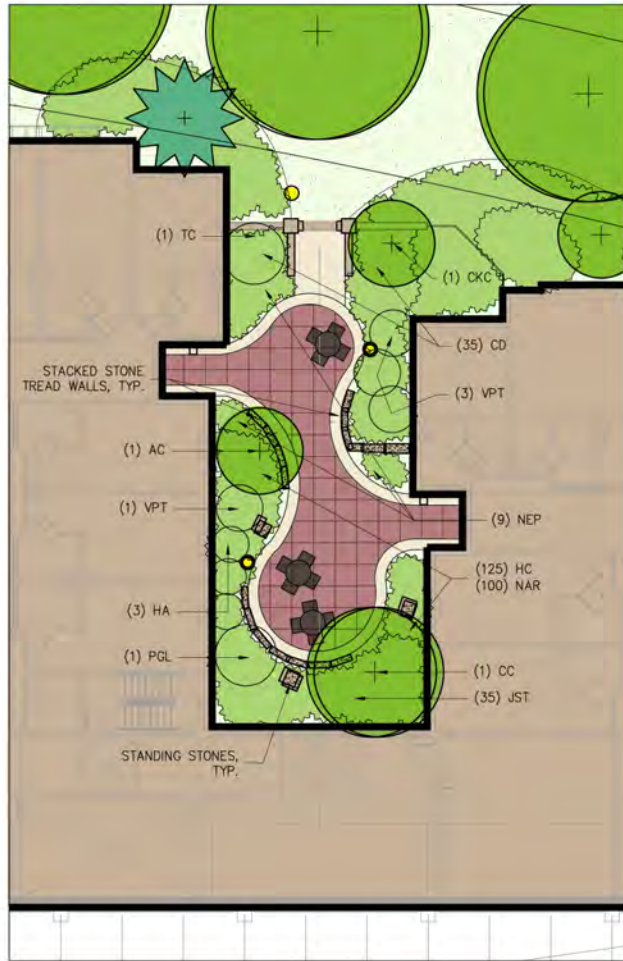

Enlarged North Courtyard

Key

SEED FOR LAWN

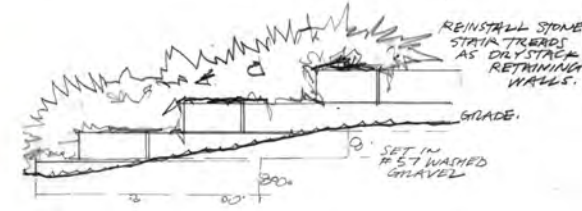

STACKED STONE TREAD WALL
NOT TO SCALE

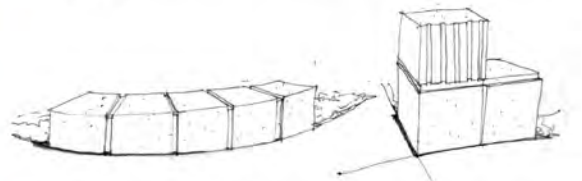

STONE ARCH PLANTER EDGE
NOT TO SCALE

McKnight Associates LTD.
812 Huron Road
Suite 417
Cleveland, OH 44115-1126

LANDSCAPE ARCHITECTURE
314.771.1800
216.771.1803-144
www.mcknightla.com

Note

1. CONTRACTOR TO VERIFY CONDITIONS AND DIMENSIONS IN THE FIELD AND NOTIFY THE OWNER OR ARCHITECT OF DISCREPANCIES.
2. CONTRACTOR IS RESPONSIBLE FOR PROVIDING PLANT QUANTITIES DETAILED ON PLAN. SCHEDULE PROVIDED FOR REFERENCE ONLY.

Plant Schedule

Key	Qty	Dom.	Retail	Parking	Office	South Court	North Court	Botanical / Common Name	Size	Cond.	Spacing
Trees											
ACON	5		6					Abies concolor / Concolor White Fir	6' Ht	B&B	16' O.C.
AP						1		Acer palmatum - Japanese Maple	4'	B&B	See Plan
AR			1					Acer rubrum 'Red Sunset' / Red Maple	2 1/2' Cal.	B&B	See Plan
AC	3				2	1		Amaranthier canadensis / Serviceberry	7' Clump	B&B	See Plan
BN	1					1		Betula nigra / River Birch	14'	B&B	See Plan
CBF					6			Carpinus betulus 'fastigiata' / Carpinus	2' Cal.	B&B	See Plan
CC							1	Pyramidal European Hornbeam			
CKC	1						1	Cercis canadensis / Redbud	1 1/2' Cal.	B&B	See Plan
GB								Cornus kousa chinensis / Kousa Dogwood	7'	B&B	See Plan
MM	1		9		4			Ginkgo biloba / Ginkgo (Male)	2 1/2'	B&B	See Plan
PAB			20					Magnolia virginiana 'Moonglow' / Moonglow Magnolia	6'	No. 5	See Plan
PGL							1	Picea abies / Norway Spruce	6'	B&B	See Plan
QR	10							Picea glauca 'Pendula' / Picea	4'	No. 5	See Plan
TC							1	Whweeping White Spruce	2 1/2' Cal.	B&B	See Plan
TD								Quercus rubra / Red Oak	6' Clump	B&B	See Plan
UL			7	4				Tsuga Canadensis / Canadian Hemlock	6' Clump	B&B	See Plan
								Taxodium distichum / Baldcypress	3 1/2' Cal.	B&B	See Plan
								Ulmus Americana 'Valley Forge' / Valley Forge Elm	2 1/2' Cal.	B&B	See Plan
Shrubs											
BTRG			60					Berberis thunbergii a. 'Rosy Glow' / Rosy Glow Barberry	15'	No. 3	2'6" O.C.
CA						3		Clethra alnifolia / Summersweet Clethra	30'	No. 3	4' O.C.
CD	50						35	Cotoneaster dammeri 'Lowfast' / Cotoneaster	12'	No. 2	3' O.C.
HA						7	3	Hydrangea 'Annabelle' / Hydrangea	24'	No. 3	3' O.C.
HQ	28						6	Hydrangia quercifolia / Oakleaf Hydrangea	18'	No. 3	4' O.C.
JPT	2							Juniperus ch. 'Spartan' / Spartan Juniper	5'	B&B	See Plan
JST					112	35	35	Juniperus s. 'tamansicifolia' / Tam Juniper	15'	No. 3	3' O.C.
RAGL	125							Rhus aromatica 'Gro-Low' / Gro-Low Fragrant Sumac	18'	No. 3	3' O.C.
RKO						10		Rosa 'Knockout' / Rose	18'	No. 2	3' O.C.
SBC	70		95	250				Spiraea x bumalda 'Anthony Waterer' / Anthony Waterer Spirea	18'	No. 3	3' O.C.
SMP			20			10		Syringa meyeri 'Palabir' / Palabir Lilac	24'	B&B	5' O.C.
VPN	28		24	8				V. plicatum 'Newport' / Newport Viburnum	18'	B&B	3' O.C.
VPT							4	V. plicatum tomentosum 'Shasta' / Shasta Doublefile Viburnum	36'	B&B	5' O.C.
Ground Cover & Grasses											
LIR	100		180	735				Liriope spicata / Lilyturf	Clump	No. 1	
PT							500	Pachysandra terminalis / Pachysandra	2 1/4'	P.P.	9' O.C.
PAN			11					Panicum virgatum 'Heavy Metal' / Heavy Metal Switch Grass	Clump	No. 2	3' O.C.
PA	25		153	3				Pennisetum alopecuroides / Fountain Grass	Clump	No. 2	3' O.C.
VM							250	Vinca minor / Periwinkle	6'	No. 1	18' O.C.
Perennials & Vines											
AO			8					Akebia quinata / Fiveleaf Akebia	Trellis	No. 3	See Plan
HOS						30		Hosta fortunei 'Royal Standard' / Hosta	Clump	No. 2	24' O.C.
HC						30	125	Hypericum calycinum / St. John's wort	Clump	No. 1	24' O.C.
NEP							9	Nepeta faassenii 'Walker's Low' / Catmint	Clump	No. 2	18' O.C.
PT			8					Parthenocissus tricuspidata / Boston Ivy	Trellis	No. 3	See Plan
Bulbs											
NAR			100				100	Narcissus sp. (3) Varieties to include: 'Scarlet O'Hara', 'Ice Follies', 'Dutch Master'	Bulb	1' O.C.	Plant varieties in clusters of (10)

COURTYARD LANDSCAPE PLANS

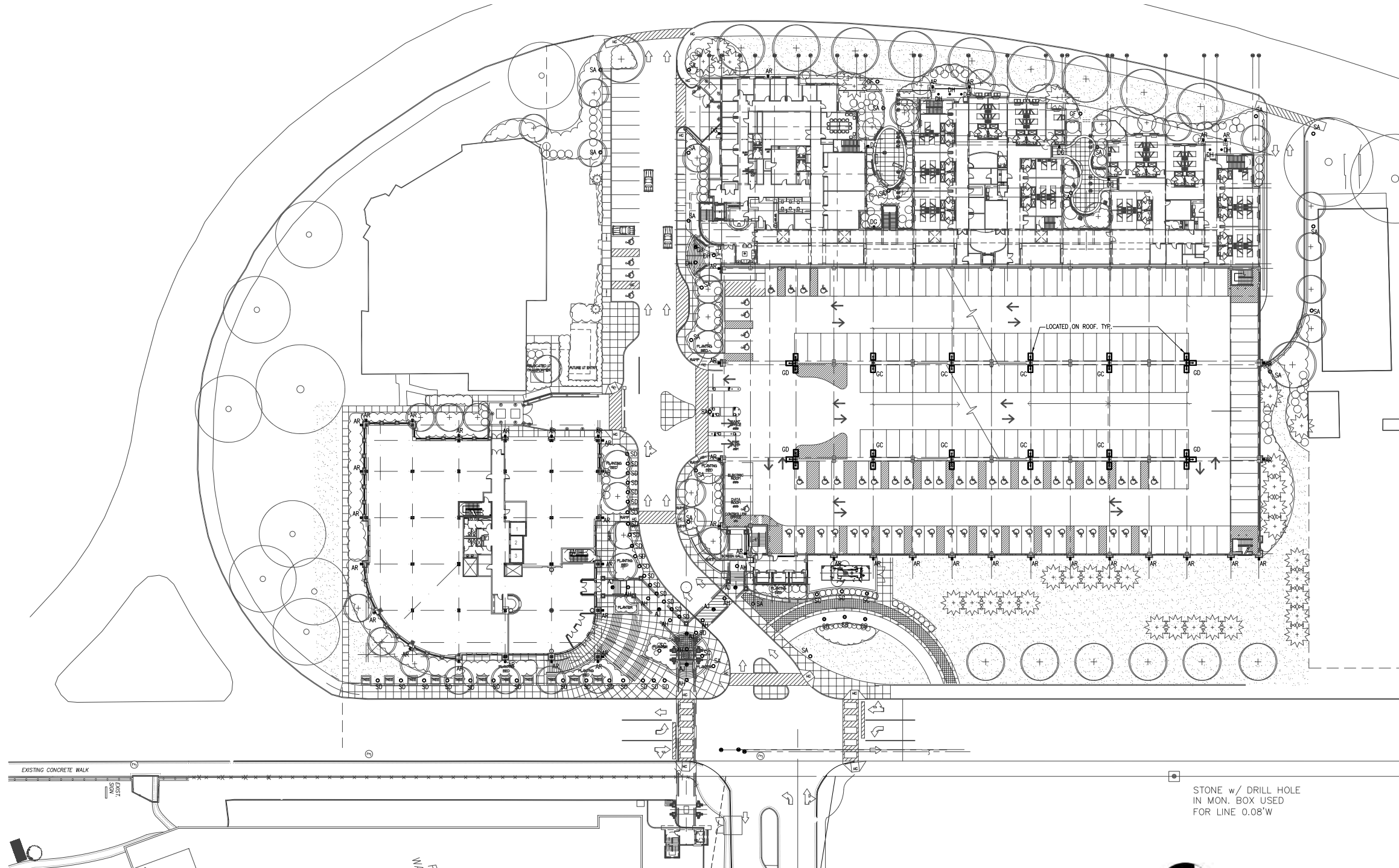

ELECTRICAL SITE PLAN



SITE LIGHTING PLAN
SCALE: 1" = 75'-0"

Site Lighting Plan - Veterans Development, LLC
Grade Level Plan - 09.26.07





TYPE "SB," "SC," "GF"

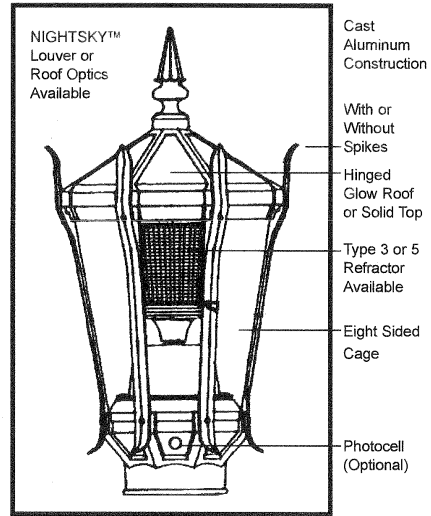

TYPE "SA," "DG"



TYPE "SD"



TYPE "GC," "GD"

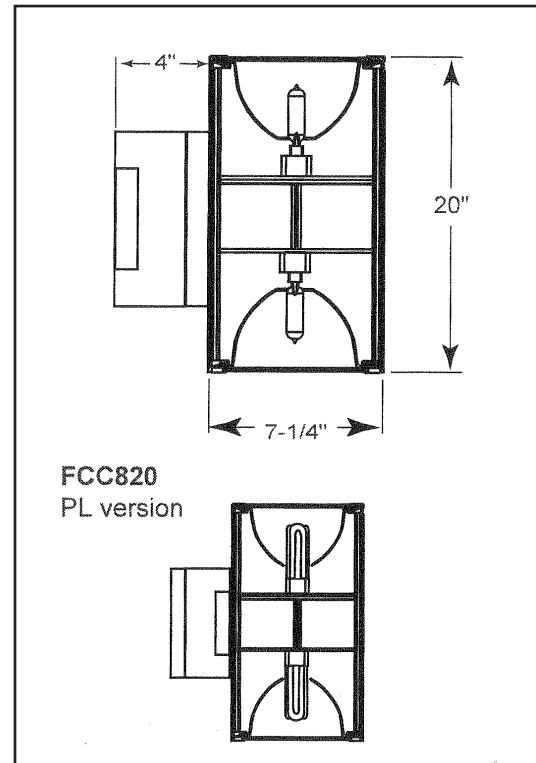



TYPE "AR"

SITE LIGHTING FIXTURE SCHEDULE						
FIXTURE TYPE	LAMPS		FIXTURE WATTAGE	VOLTAGE	DESCRIPTION	MANUFACTURER AND CATALOG NUMBER
	No.	TYPE				
SA	1	250WMH	275	277	SINGLE HEAD DECORATIVE SITE LIGHTING FIXTURE ON 16 FOOT POLE. FINISH AND DISTRIBUTION TYPE TO BE DETERMINED	STERNBERG MAIN STREET SERIES
SB	1	100WMH	125	277	IN-GROUND HID FLAG UP LIGHT.	KIM: DBF SERIES
SC	1	175WMH	210	277	IN-GROUND UP LIGHT	KIM: DBF SERIES
SD	1	100WMH	125	277	DECORATIVE CONCRETE ILLUMINATED BOLLARD. HID FIXTURE MOUNTED TO TOP OF STRUCTURAL POURED CONCRETE BOLLARD. 18" DIAMETER.	AAL CB 18 SERIES
AH	1	1-100WMH	125	277	10" ROUND RECESSED LENS H.I.D. DOWNLIGHT. U.L. DAMP LOCATION LISTED. FLUSH MOUNTED GLASS FRESNAL LENS.	PRESCOLITE: LFHL-H10-100MH-100MHFE-10FFR
AJ	2	1-100WMH 1-100WQTZ	225	277	SAMES AS TYPE "AH" EXCEPT WITH EMERGENCY 100W QUARTZ RE-STRIKE LAMP.	PRESCOLITE: LFHL-H10-100MH-QR-100MFE-10FFR
DH	1	100WMH	125	120	10" ROUND RECESSED LENS H.I.D. DOWNLIGHT. U.L. DAMP LOCATION LISTED. FLUSH MOUNTED GLASS FRESNAL LENS.	PRESCOLITE: LFHL-H10-100MH-100MHFE-10FFR
DJ	2	1-100WMH 1-100WQTZ	225	120	SAMES AS TYPE "AH" EXCEPT WITH EMERGENCY 100W QUARTZ RE-STRIKE LAMP.	PRESCOLITE: LFHL-H10-100MH-QR-100MFE-10FFR
GC	2	400MH	930	277	DOUBLE HEAD POLE MOUNTED HID FIXTURE. BRONZE FINISH. MOUNTED ON 18' STRAIGHT ROUND ALUMINUM POLE.	KIM: 2B/AR4/400MH-277V/DB-P/RS-18-40-B-CX-DB-Q40
GD	3	400MH	1395	277	TRIPLE HEAD POLE MOUNTED HID FIXTURE. BRONZE FINISH. MOUNTED ON 18' STRAIGHT ROUND ALUMINUM POLE.	KIM: 3T/AR4/400MH-277V/DB-P/RS-18-B-DX-DB-Q40
GF	1	100WMH	125	120	GROUND MOUNTED HID FLOOD LIGHT	KIM: DBF SERIES
AR	2	70WMH	200	277	EXTERIOR HID WALL SCONCE. COLD WEATHER BALLAST, U.L. WET LOCATION LISTED. BRONZE FINISH. UP AND DOWN LIGHT COMPONENT.	FC LIGHTING FCC 820
DG	1	70WMH	100	120	EXTERIOR SURFACE WALL MOUNTED H.I.D. DECORATIVE FIXTURE. U.L. WET LOCATION LISTED.	STERNBERG MAIN STREET SERIES
DH	1	1-100WMH	120	120	10" ROUND RECESSED LENS H.I.D. DOWNLIGHT. U.L. DAMP LOCATION LISTED. FLUSH MOUNTED GLASS FRESNAL LENS.	PRESCOLITE: LFHL-H10-100MH-100MHFE-10FFR



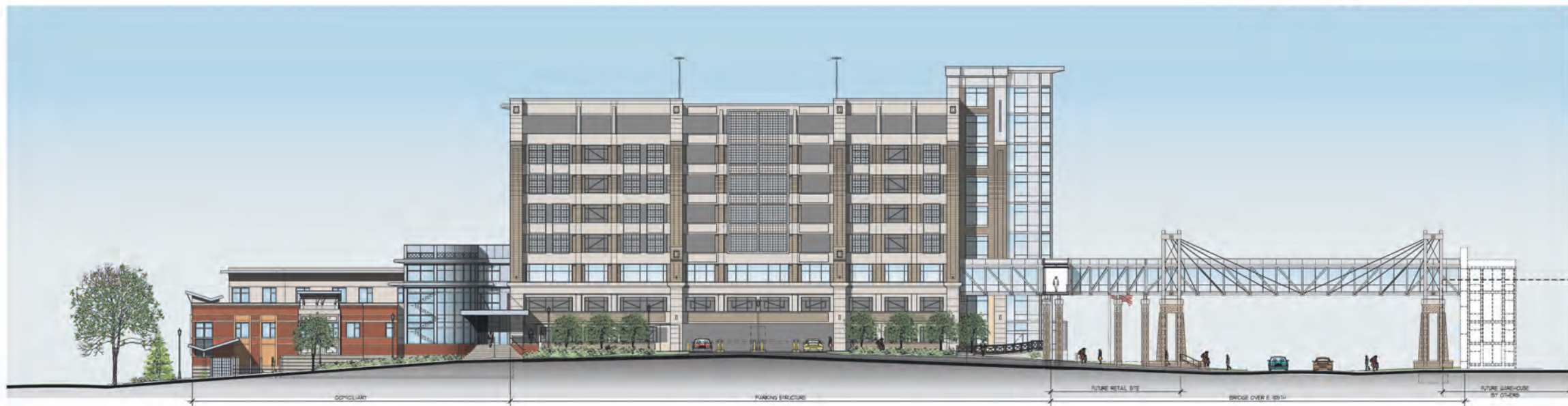

 SITE SECTION AT NEW ROAD
 LOOKING SOUTH
 SCALE: 1" = 50'-0"

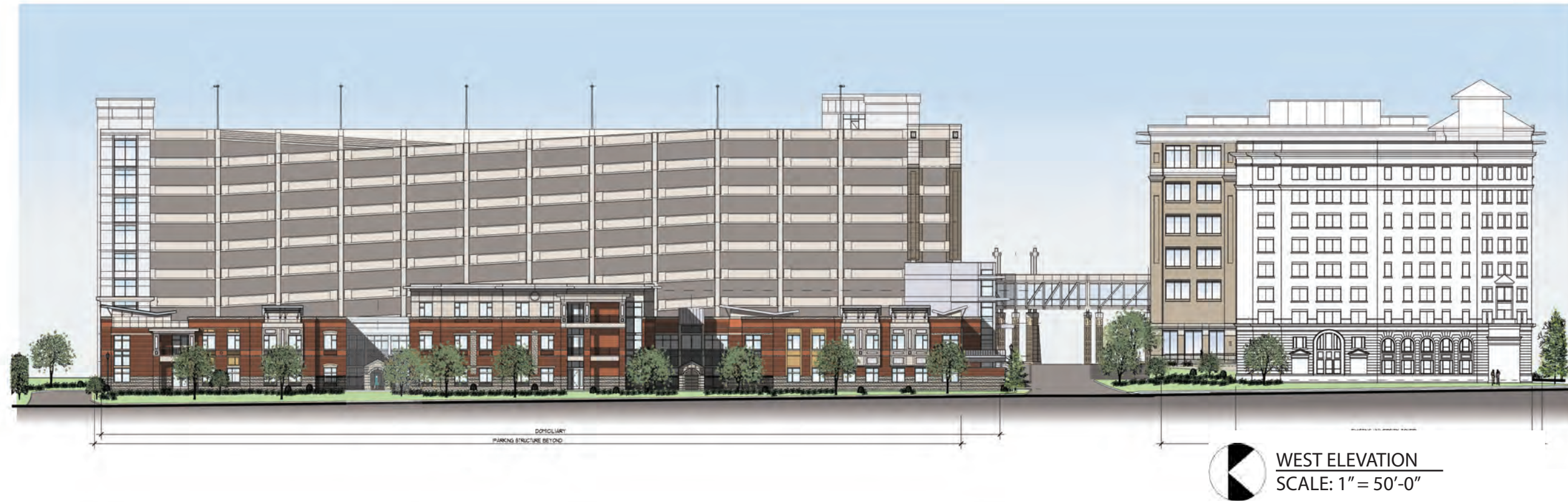

 SITE SECTION AT NEW ROAD
 LOOKING NORTH
 SCALE: 1" = 50'-0"

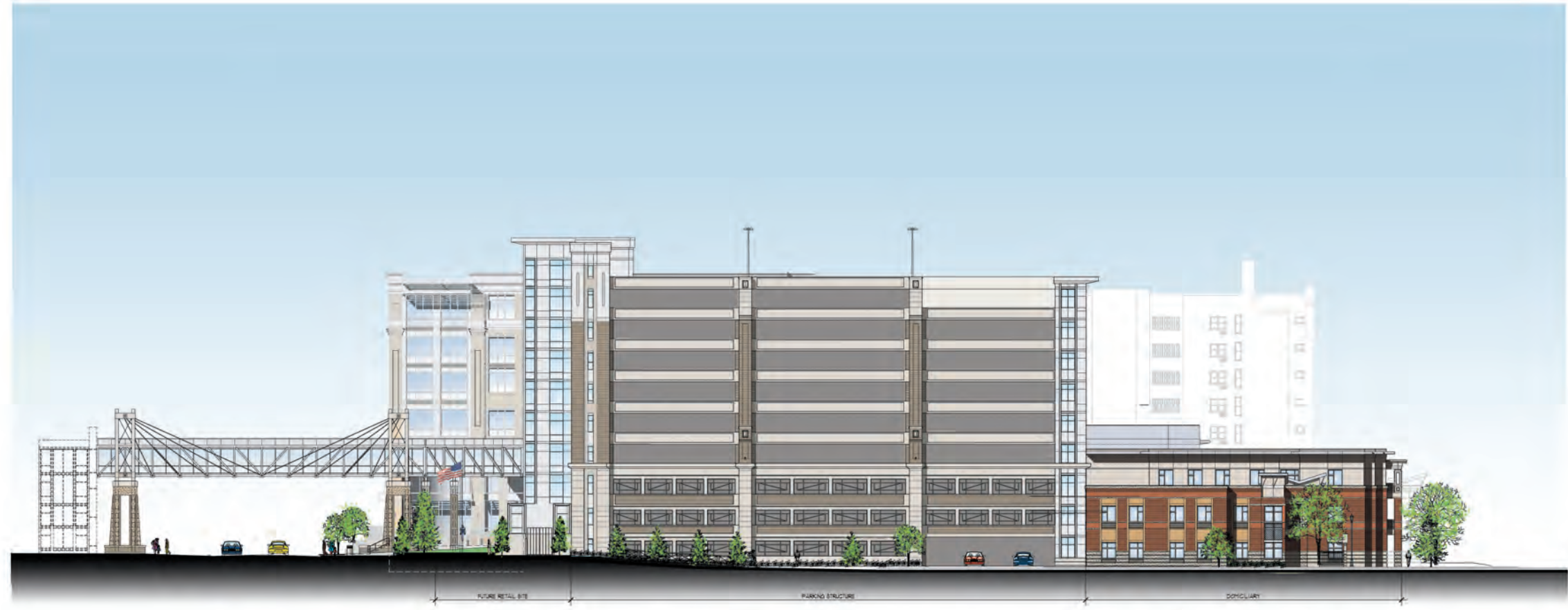

Overall Site Elevations - Veterans Development, LLC
 East and West Elevations - 09.26.07



 NORTH ELEVATION
SCALE: 1" = 50'-0"

Overall Site Elevations - Veterans Development, LLC
North Elevation - 09.26.07

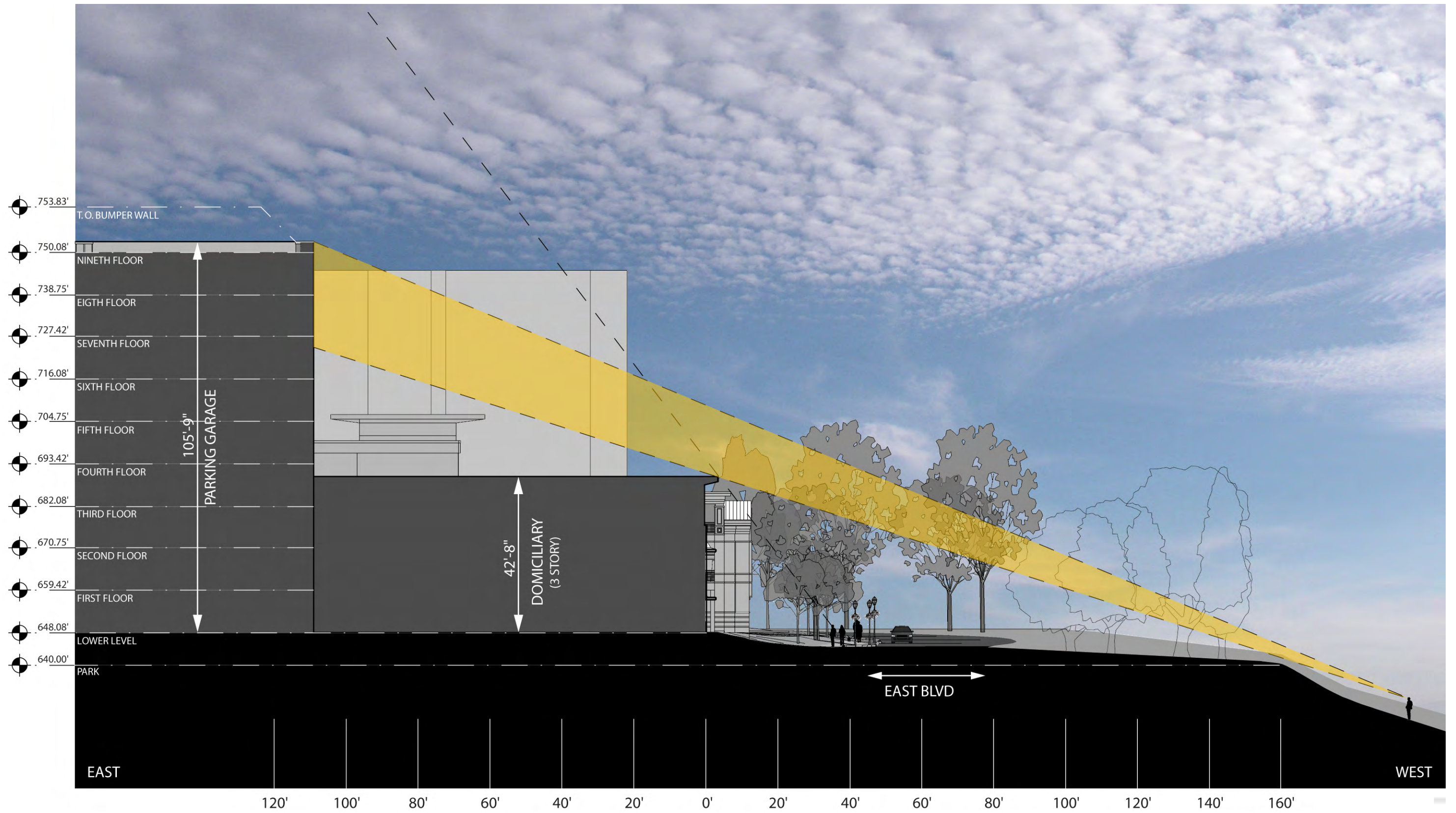

 SITE SECTION

Overall Site Section - Veterans Development, LLC
 Through Domiciliary and Parking Structure - 09.26.07

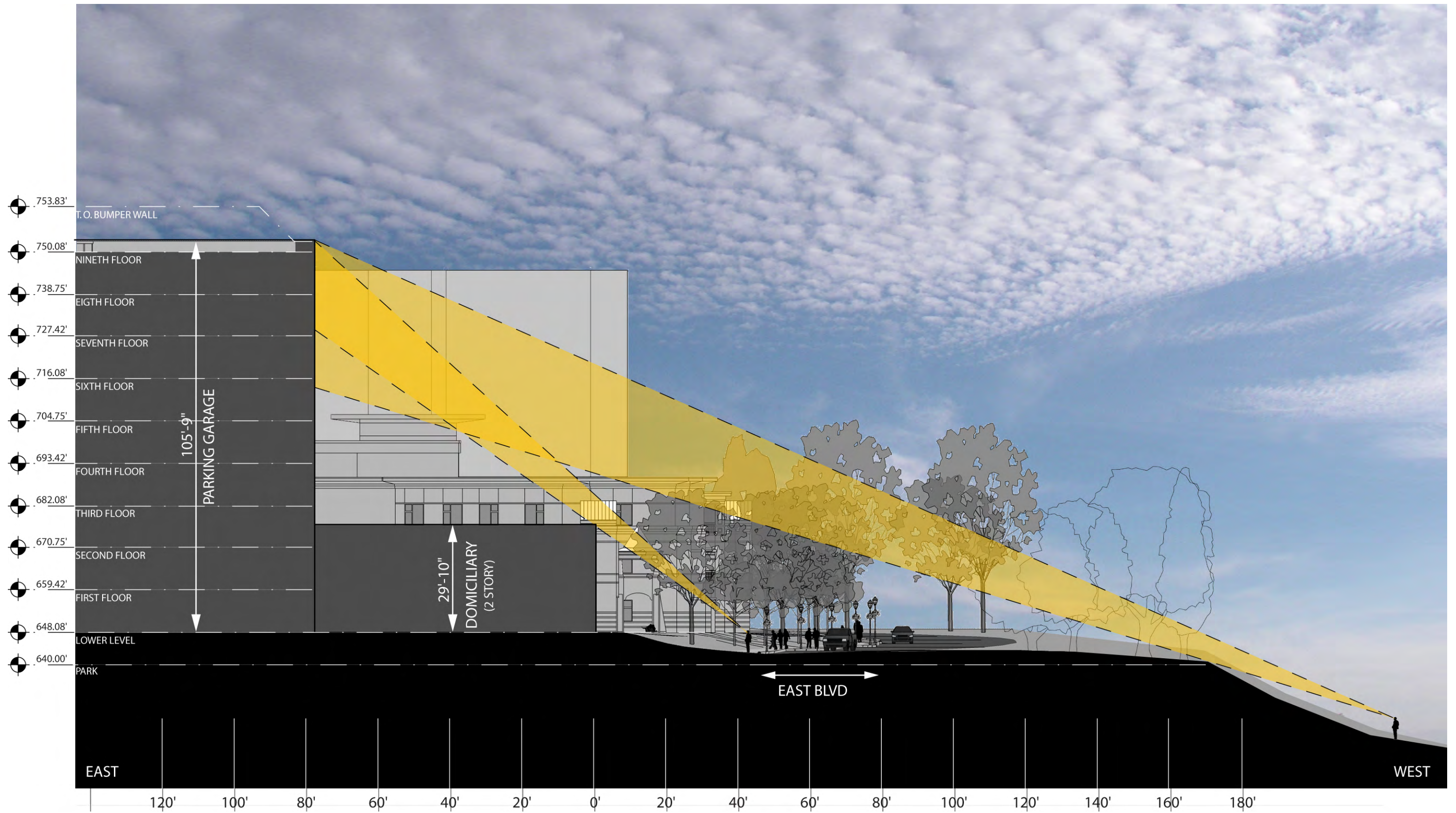

 SITE SECTION

Overall Site Section - Veterans Development, LLC
 Through Domiciliary and Parking Structure - 09.26.07

DETAILS

- 1 STONE UNIT PANELS ON METAL CLIPS
- 2 CONTINUOUS STONE BAND W/ 1/2" RAD. BULLNOSE EDGE
- 3 STANDARD FACEBRICK ON MET. BRICK TIES. SEE ELEV. FOR COLOR DIFFERENCE LOCATIONS
- 4 CONTINUOUS STONE BAND
- 5 CONTINUOUS BRICK SOLDIER COURSE
- 6 PRECAST CONCRETE COPING W/SLOPED TOP
- 7 FIXED ALUMINUM STOREFRONT SYSTEM W/ 1" LOW-E INSULATED GLASS AND KYNAR FINISH. COLOR BY ARCHITECT. - SEE ELEVATIONS FOR SPANDREL GLASS LOCATIONS (NOTE: LOW-E NOT REQUIRED * PARKING STRUCTURE)
- 8 8" STONE HEADER
- 9 HARDI-PLANK PANEL, FTD.
- 10 CONTINUOUS PROJECTED HARDI-PLANK TRIM BAND
- 11 CONTINUOUS 2x3 GA. ALUMINUM COPING W/KYNAR FINISH - COLOR BY ARCHITECT
- 12 STONE WINDOW SILL W/SLOPED TOP
- 13 STANDING BEAM ROOFING SYSTEM, COLOR BY ARCHITECT
- 14 METAL GUARDRAIL - 3'-6" AFF WITH 1" POCKETS # 3/16" O.C., ANCHOR SECURELY TO ADJUTING WALL SURFACES
- 15 PRE-FABRICATED SURFACE MOUNTED ALUMINUM SUNSCREEN, REFER TO SPECIFICATIONS
- 16 METAL PANELS W/ CONCEALED SILICONE JOINTS # BAKED ENAMEL FINISH - COLOR BY ARCHITECT
- 17 PRECAST CONCRETE CORNICE ELEMENT, REFER TO PRECAST PROFILES
- 18 METAL PORCH CANOPY W/ALUM. COPING AND STEEL SUPPORTS TIED TO BUILDING STRUCTURE, REFER TO STRUCT. DUGS FOR DETAILS, TYP.
- 19 ALUMINUM GLASS STOREFRONT ENTRY DOOR W/TEMPERED LOW-E INSULATED GLASS, INTEGRAL TO STOREFRONT WINDOW SYSTEM
- 20 CAST-IN-PLACE CONCRETE BUMPER WALL BEAM
- 21 CAST-IN-PLACE CONCRETE BUMPER WALL BEAM W/FACEBRICK INFILL
- 22 STEEL I-BEAM, FTD. # WINDOW HEADS AND JAMBS
- 23 PRECAST CONCRETE ACCENT BAND
- 24 RAISED PRECAST CONCRETE ACCENT PANEL
- 25 METAL PANEL CORNICE ELEMENT W/ CONCEALED SILICONE JOINTS # BAKED ENAMEL FINISH - COLOR BY ARCHITECT
- 26 PRECAST CONCRETE PANELS W/ 1/2" GROOVE RECESSES
- 27 SURFACE MOUNTED GRIDDED DESIGN METAL LOUVER - OPEN AIR TO PARKING STRUCTURE SPACE BEYOND, FTD.
- 28 STANDING BEAM CANOPY TIED TO BUILDING STRUCTURE - REFER TO STRUCT. DUGS FOR DETAILS, TYP.
- 29 OPEN DECORATIVE PREFINISHED ALUMINUM FRAME SYSTEMS, FTD.
- 30 ALUMINUM MECHANICAL LOUVER - FINISH TO MATCH ADJACENT SURFACE
- 31 PRECAST CONCRETE WINDOW SILL W/SLOPED TOP
- 32 PAINTED STEEL AINING W/STEEL CABLES SECURED TO BUILDING STRUCTURE. REFER TO STRUCT. DUGS.
- 33 WALL MTD. LIGHT FIXTURE. SEE ELECTRICAL DRAWINGS
- 34 METAL SUN SHADE/OVERHANG
- 35 METAL BRACKETS # PLATES



NORTH ELEVATION
SCALE: 1" = 20'-0"



SOUTH ELEVATION
SCALE: 1" = 20'-0"

Proposed Domiciliary - Veterans Development, LLC
North and South Elevations - 09.26.07

SYMBOL LEGEND

- 1 STONE UNIT PANELS ON METAL CLIPS
- 2 CONTINUOUS STONE BAND @ 1/2" RAD. BULLNOSE EDGE
- 3 STANDARD FACEBRICK ON MTL. BRICK TIES, SEE ELEV. FOR COLOR DIFFERENCE LOCATIONS
- 4 CONTINUOUS STONE BAND
- 5 CONTINUOUS BRICK SOLDIER COURSE
- 6 PRECAST CONCRETE COPING @SLOPED TOP
- 7 FIXED ALUMINUM STOREFRONT SYSTEM @ 1" LOU-E INSULATED GLASS AND KYNAR FINISH. COLOR BY ARCHITECT - SEE ELEVATIONS FOR SPANDREL GLASS LOCATIONS (NOTE: LOU-E NOT REQUIRED * PARKING STRUCTURE)
- 8 8" STONE HEADER
- 9 HARDI-PLANK PANEL, PTD.
- 10 CONTINUOUS PROJECTED HARDI-PLANK TRIM BAND
- 11 CONTINUOUS Ø63 GA. ALUMINUM COPING W/KYNAR FINISH - COLOR BY ARCHITECT
- 12 STONE WINDOW SILL @SLOPED TOP
- 13 STANDING BEAM ROOFING SYSTEM, COLOR BY ARCHITECT
- 14 METAL GUARDRAIL # 3'-6" AFF WITH 1" FROCKETS # 3 1/2" O.C., ANCHOR SECURELY TO ADJUTING WALL SURFACES
- 15 PRE-FABRICATED SURFACE MOUNTED ALUMINUM SUNSCREEN, REFER TO SPECIFICATIONS
- 16 METAL PANELS W/CONCEALED SILICONE JOINTS # BAKED ENAMEL FINISH - COLOR BY ARCHITECT
- 17 PRECAST CONCRETE CORNICE ELEMENT, REFER TO PRECAST PROFILES
- 18 METAL PORCH CANOPY WALLM. COPING AND STEEL SUPPORTS TIED TO BUILDING STRUCTURE, REFER TO STRUCT. DUGS. FOR DETAILS, TYP.
- 19 ALUMINUM/GLASS STOREFRONT ENTRY DOOR W/TEMPERED LOU-E INSULATED GLASS, INTEGRAL TO STOREFRONT WINDOW SYSTEM
- 20 CAST-IN-PLACE CONCRETE BUMPER WALL/BEAM
- 21 CAST-IN-PLACE CONCRETE BUMPER WALL/BEAM W/FACEBRICK INFILL
- 22 STEEL I-BEAM, PTD. # WINDOW HEADS AND JAMBS
- 23 PRECAST CONCRETE ACCENT BAND
- 24 RAISED PRECAST CONCRETE ACCENT PANEL
- 25 METAL PANEL CORNICE ELEMENT W/CONCEALED SILICONE JOINTS # BAKED ENAMEL FINISH - COLOR BY ARCHITECT
- 26 PRECAST CONCRETE PANELS W/2" GROOVE RECESSES
- 27 SURFACE MOUNTED GRIDDED DESIGN METAL LOUVER - OPEN AIR TO PARKING STRUCTURE SPACE BEYOND, PTD.
- 28 STANDING BEAM CANOPY TIED TO BUILDING STRUCTURE - REFER TO STRUCT. DUGS. FOR DETAILS, TYP.
- 29 OPEN DECORATIVE PREFINISHED ALUMINUM FRAME SYSTEMS, PTD.
- 30 ALUMINUM MECHANICAL LOUVER - FINISH TO MATCH ADJACENT SURFACE
- 31 PRECAST CONCRETE WINDOW SILL @SLOPED TOP
- 32 PAINTED STEEL AIMING W/STEEL CABLES, SECURED TO BUILDING STRUCTURE. REFER TO STRUCT. DUGS.

- 33 WALL MTD. LIGHT FIXTURE, SEE ELECTRICAL DRAWINGS
- 34 METAL SUN SHADE/OVERHANG
- 35 PTD. STL. BRACKETS # PLATES



PARTIAL WEST ELEVATION
SCALE: 1" = 20'-0"



PARTIAL WEST ELEVATION
SCALE: 1" = 20'-0"

Proposed Domiciliary - Veterans Development, LLC
West Elevation - 09.26.07



SYMBOL LEGEND

- 1 STONE UNIT PANELS ON METAL CLIPS
- 2 CONTINUOUS STONE BAND W/ 1/2" RAD. BULLNOSE EDGE
- 3 STANDARD FACEBRICK ON HTL. BRICK TIES. SEE ELEV. FOR COLOR DIFFERENCE LOCATIONS
- 4 CONTINUOUS STONE BAND
- 5 CONTINUOUS BRICK SOLDIER COURSE
- 6 PRECAST CONCRETE COPING W/SLOPED TOP
- 7 FIXED ALUMINUM STOREFRONT SYSTEM W/ LOW-E INSULATED GLASS AND ANODIZED FINISH. COLOR BY ARCHITECT - SEE ELEVATIONS FOR SPANDREL GLASS LOCATIONS. NOTE: LOW-E GLASS NOT REQUIRED # PARKING STRUCTURE SPANDREL GLASS LOCATIONS
- 8 8" STONE HEADER
- 9 HARDI-PLANK PANEL, PTD.
- 10 CONTINUOUS PROJECTED HARDI-PLANK TRIM BAND
- 11 CONTINUOUS 2x3 1/2 ALUMINUM COPING W/KYNAR FINISH + COLOR BY ARCHITECT
- 12 STONE WINDOW SILL W/SLOPED TOP
- 13 STANDING BEAM ROOFING SYSTEM. COLOR BY ARCHITECT
- 14 METAL GUARDRAIL # 3-1/2" JFF WITH 1" PICKETS # 3 1/2" OC, ANCHOR SECURELY TO ADJUTING WALL SURFACES
- 15 PRE-FABRICATED SURFACE MOUNTED ALUMINUM SUNSCREEN. REFER TO SPECIFICATIONS
- 16 METAL PANELS W/ SILICONE JOINTS. KYNAR FINISH + COLOR BY ARCHITECT
- 17 PRECAST CONCRETE CORNICE ELEMENT. REFER TO PRECAST PROFILES
- 18 METAL PORCH CANOPY W/ALUM. COPING AND STEEL SUPPORTS TIED TO BUILDING STRUCTURE. REFER TO STRUCT. DUGS FOR DETAILS. TYP.
- 19 ALUMINUM/GLASS STOREFRONT ENTRY DOOR W/TEMPERED LOW-E INSULATED GLASS. INTEGRAL TO STOREFRONT WINDOW SYSTEM
- 20 CAST-IN-PLACE CONCRETE BUFFER WALL/BEAM
- 21 CAST-IN-PLACE CONCRETE BUFFER WALL/BEAM W/FACEBRICK INFILL
- 22 STEEL I-BEAM, PTD. # WINDOW HEADS AND JAMBS
- 23 PRECAST CONCRETE ACCENT BAND
- 24 RAISED PRECAST CONCRETE ACCENT PANEL
- 25 METAL PANEL CORNICE ELEMENT W/CONCEALED SILICONE JTS + BAKED ENAMEL FINISH + COLOR BY ARCHITECT
- 26 PRECAST CONCRETE PANELS W/1" GROOVE RECESSES
- 27 SURFACE MOUNTED GRIDDED DESIGN METAL LOUVER - OPEN AIR TO PARKING STRUCTURE SPACE BEYOND. PTD.
- 28 STANDING BEAM CANOPY TIED TO BUILDING STRUCTURE - REFER TO STRUCT. DUGS FOR DETAILS. TYP.
- 29 OPEN DECORATIVE PREFINISHED ALUMINUM FRAME SYSTEMS, PTD.
- 30 ALUMINUM MECHANICAL LOUVER - FINISH TO MATCH ADJACENT SURFACE
- 31 PRECAST CONCRETE WINDOW SILL W/SLOPED TOP
- 32 PAINTED STEEL. ANCHOR W/STEEL CABLES. SECURED TO BUILDING STRUCTURE. REFER TO STRUCT. DUGS



NORTH ELEVATION
SCALE: 1" = 20'-0"

Proposed Office Building - Veterans Development, LLC
North Elevation - 09.26.07

SYMBOL LEGEND

- 1 STONE UNIT PANELS ON METAL CLIPS
- 2 CONTINUOUS STONE BAND W/ 1/2" RAD. BULLNOSE EDGE
- 3 STANDARD FACE BRICK ON HTL. BRICK TBS. SEE ELEV. FOR COLOR DIFFERENCE LOCATIONS
- 4 CONTINUOUS STONE BAND
- 5 CONTINUOUS BRICK SOLDIER COURSE
- 6 PRECAST CONCRETE COPING W/ SLOPED TOP
- 7 FIXED ALUMINUM STOREFRONT SYSTEM W/ 1" LOW-E INSULATED GLASS AND ANODIZED FINISH. COLOR BY ARCHITECT - SEE ELEVATIONS FOR SPANDREL GLASS LOCATIONS (NOTE: LOW-E GLASS NOT REQUIRED - PARKING STRUCTURE)
- 8 8" STONE HEADER
- 9 HARD-PLANK PANEL, PTD.
- 10 CONTINUOUS PROJECTED HARD-PLANK TRIM BAND
- 11 CONTINUOUS 2x3 GA. ALUMINUM COPING W/ KYNAR FINISH - COLOR BY ARCHITECT
- 12 STONE WINDOW SILL W/ SLOPED TOP
- 13 STANDING BEAM ROOFING SYSTEM, COLOR BY ARCHITECT
- 14 METAL GUARDRAIL, # 3"-6" AFF WITH 1" PICKETS # 3 1/2" O.C., ANCHOR SECURELY TO ADJUTING WALL SURFACES
- 15 PRE-FABRICATED SURFACE MOUNTED ALUMINUM GUNSCREEN. REFER TO SPECIFICATIONS
- 16 METAL PANELS W/ SILICONE JOINTS, KYNAR FINISH - COLOR BY ARCHITECT
- 17 PRECAST CONCRETE CORNICE ELEMENT. REFER TO PRECAST PROFILES
- 18 METAL PORCH CANOPY W/ ALUM. COPING AND STEEL SUPPORTS TIED TO BUILDING STRUCTURE. REFER TO STRUCT. DUGS FOR DETAILS, TYP.
- 19 ALUMINUM GLASS STOREFRONT ENTRY DOOR W/ TEMPERED LOW-E INSULATED GLASS. INTEGRAL TO STOREFRONT WINDOW SYSTEM
- 20 CAST-IN-PLACE CONCRETE BUMPER WALL BEAM
- 21 CAST-IN-PLACE CONCRETE BUMPER WALL BEAM W/ FACE BRICK INFILL
- 22 STEEL I-BEAM, PTD. # WINDOW HEADS AND JAMBS
- 23 PRECAST CONCRETE ACCENT BAND
- 24 RAISED PRECAST CONCRETE ACCENT PANEL
- 25 METAL PANEL CORNICE ELEMENT W/ CONCEALED SILICONE JTS. + BAKED ENAMEL FINISH - COLOR BY ARCHITECT
- 26 PRECAST CONCRETE PANELS W/ GROOVE RECESSES
- 27 SURFACE MOUNTED GRIDDED DESIGN METAL LOUVER - OPEN AIR TO PARKING STRUCTURE SPACE BEYOND, PTD.
- 28 STANDING BEAM CANOPY TIED TO BUILDING STRUCTURE - REFER TO STRUCT. DUGS FOR DETAILS, TYP.
- 29 OPEN DECORATIVE PREFINISHED ALUMINUM FRAME SYSTEMS, PTD.
- 30 ALUMINUM MECHANICAL LOUVER - FINISH TO MATCH ADJACENT SURFACE
- 31 PRECAST CONCRETE WINDOW SILL W/ SLOPED TOP
- 32 PAINTED STEEL AWNING W/ STEEL GABLES, SECURED TO BUILDING STRUCTURE. REFER TO STRUCT. DUGS.
- 33 WALL MTD. LIGHT FIXTURE, SEE ELECTRICAL DRAWINGS.



 SOUTH ELEVATION
SCALE: 1" = 20'-0"

Proposed Office Building - Veterans Development, LLC
South Elevation - 09.26.07

SYMBOL LEGEND

- 1 STONE UNIT PANELS ON METAL CLIPS
- 2 CONTINUOUS STONE BAND W/ 1/2" RAD. BULLNOSE EDGE
- 3 STANDARD FACEBRICK ON MTL. BRICK TIES. SEE ELEV. FOR COLOR DIFFERENCE LOCATIONS
- 4 CONTINUOUS STONE BAND
- 5 CONTINUOUS BRICK SOLDER COURSE
- 6 PRECAST CONCRETE CORNING W/SLOPED TOP

- 7 FIXED ALUMINUM STOREFRONT SYSTEM W/ 1" LOW-E INSULATED GLASS AND ANODIZED FINISH. COLOR BY ARCHITECT - SEE ELEVATIONS FOR SPANDREL GLASS LOCATIONS (NOTE: LOW-E GLASS NOT REQUIRED * PARKING STRUCTURE)
- 8 8" STONE HEADER
- 9 HARDI-PLANK PANEL. FTD.
- 10 CONTINUOUS PROJECTED HARDI-PLANK TRIM BAND
- 11 CONTINUOUS #63 GA. ALUMINUM CORNING W/KYNAR FINISH - COLOR BY ARCHITECT
- 12 STONE WINDOW SILL W/SLOPED TOP
- 13 STANDING BEAM ROOFING SYSTEM. COLOR BY ARCHITECT

- 14 METAL GUARDRAIL, # 3" x 4" JET WITH 1" RICKETS # 3/16" OD, ANCHOR SECURELY TO ABUTTING WALL SURFACES
- 15 PRE-FABRICATED SURFACE MOUNTED ALUMINUM SUNSCREEN. REFER TO SPECIFICATIONS
- 16 METAL PANELS W/ SILICONE JOINTS, KYNAR FINISH - COLOR BY ARCHITECT
- 17 PRECAST CONCRETE CORNING ELEMENT, REFER TO PRECAST PROFILES
- 18 METAL PORCH CANOPY WALL, CORNING AND STEEL SUPPORTS TIED TO BUILDING STRUCTURE. REFER TO STRUCT. DUGS FOR DETAILS, TYP.
- 19 ALUMINUM GLASS STOREFRONT ENTRY DOOR W/TEMPERED LOW-E INSULATED GLASS, INTEGRAL TO STOREFRONT WINDOW SYSTEM
- 20 CAST-IN-PLACE CONCRETE BUMPER WALL/BEAM

- 21 CAST-IN-PLACE CONCRETE BUMPER WALL/BEAM W/FACED BRICK INFILL
- 22 STEEL I-BEAM, FTD. # WINDOW HEADS AND JAMBS
- 23 PRECAST CONCRETE ACCENT BAND
- 24 RAISED PRECAST CONCRETE ACCENT PANEL
- 25 METAL PANEL CORNING ELEMENT W/ CONCEALED SILICONE, 7/8" x BAKED ENAMEL FINISH - COLOR BY ARCHITECT
- 26 PRECAST CONCRETE PANELS W/ 1" GROOVE RECESSES

- 27 SURFACE MOUNTED GRIDDED DESIGN METAL LOUVER - OPEN AIR TO PARKING STRUCTURE SPACE BEYOND, FTD.
- 28 STANDING BEAM CANOPY TIED TO BUILDING STRUCTURE - REFER TO STRUCT. DUGS FOR DETAILS, TYP.
- 29 OPEN DECORATIVE PREFINISHED ALUMINUM FRAME SYSTEMS, FTD.
- 30 ALUMINUM MECHANICAL LOUVER - FINISH TO MATCH ADJACENT SURFACE
- 31 PRECAST CONCRETE WINDOW SILL W/SLOPED TOP
- 32 PAINTED STEEL ALONG W/STEEL CABLES SECURED TO BUILDING STRUCTURE. REFER TO STRUCT. DUGS.
- 33 WALL MTD. LIGHT FIXTURE. SEE ELECTRICAL DRAWINGS.



 EAST ELEVATION
SCALE: 1" = 20'-0"

Proposed Office Building - Veterans Development, LLC
East Elevation - 09.26.07



SYMBOL LEGEND

- 1 STONE UNIT PANELS ON METAL CLIPS
- 2 CONTINUOUS STONE BAND W/ 1/2" RAD. BULLNOSE EDGE
- 3 STANDARD FACEBRICK ON MET. BRICK TIES, SEE ELEV. FOR COLOR DIFFERENCE LOCATIONS
- 4 CONTINUOUS STONE BAND
- 5 CONTINUOUS BRICK SOLDIER COURSE
- 6 PRECAST CONCRETE COPING W/ SLOPED TOP
- 7 FIXED ALUMINUM STOREFRONT SYSTEM W/ 1" LOW-E INSULATED GLASS AND ANODIZED FINISH COLOR BY ARCHITECT - SEE ELEVATIONS FOR SPANDREL GLASS LOCATIONS (NOTE: LOW-E GLASS NOT REQUIRED @ PARKING STRUCTURE) SPANDREL GLASS LOCATIONS
- 8 8" STONE HEADER
- 9 HARD-PLANK PANEL, PTD.
- 10 CONTINUOUS PROJECTED HARD-PLANK TRIM BAND
- 11 CONTINUOUS #63 GA. ALUMINUM COPING W/ KYNAR FINISH - COLOR BY ARCHITECT
- 12 STONE WINDOW SILL W/ SLOPED TOP
- 13 STANDING SEAM ROOFING SYSTEM, COLOR BY ARCHITECT
- 14 METAL GUARDRAIL, # 3" x 6" JRF WITH 1" PICKETS @ 3 1/2' O.C., ANCHOR SECURELY TO ABUTTING WALL SURFACES
- 15 PRE-FABRICATED SURFACE MOUNTED ALUMINUM SUNSCREEN, REFER TO SPECIFICATIONS
- 16 METAL PANELS W/ SILICONE JOINTS, KYNAR FINISH - COLOR BY ARCHITECT
- 17 PRECAST CONCRETE CORNICE ELEMENT, REFER TO PRECAST PROFILES
- 18 METAL PORCH CANOPY W/ ALUM. COPING AND STEEL SUPPORTS TIED TO BUILDING STRUCTURE, REFER TO STRUCT. DUGS FOR DETAILS, TYP.
- 19 ALUMINUM GLASS STOREFRONT ENTRY DOOR W/ TEMPERED LOW-E INSULATED GLASS, INTEGRAL TO STOREFRONT WINDOW SYSTEM
- 20 CAST-IN-PLACE CONCRETE BUMPER WALL/BEAM
- 21 CAST-IN-PLACE CONCRETE BUMPER WALL/BEAM W/ FACEBRICK INFILL
- 22 STEEL I-BEAM, PTD. @ WINDOW HEADS AND JAMBS
- 23 PRECAST CONCRETE ACCENT BAND
- 24 RAISED PRECAST CONCRETE ACCENT PANEL
- 25 METAL PANEL CORNICE ELEMENT W/ CONCEALED SILICONE JTS. @ BAKED ENAMEL FINISH - COLOR BY ARCHITECT
- 26 PRECAST CONCRETE PANELS W/ 1" GROOVE RECESSES
- 27 SURFACE MOUNTED GRIDDED DESIGN METAL LOUVER - OPEN AIR TO PARKING STRUCTURE SPACE BEYOND, PTD.
- 28 STANDING SEAM CANOPY TIED TO BUILDING STRUCTURE - REFER TO STRUCT. DUGS FOR DETAILS, TYP.
- 29 OPEN DECORATIVE PREFINISHED ALUMINUM FRAME SYSTEMS, PTD.
- 30 ALUMINUM MECHANICAL LOUVER - FINISH TO MATCH ADJACENT SURFACE
- 31 PRECAST CONCRETE WINDOW SILL W/ SLOPED TOP
- 32 PAINTED STEEL ANCHOR W/ STEEL CABLES SECURED TO BUILDING STRUCTURE, REFER TO STRUCT. DUGS
- 33 WALL MTD. LIGHT FIXTURE, SEE ELECTRICAL DRAWINGS



WEST ELEVATION
SCALE: 1" = 20'-0"

Proposed Office Building - Veterans Development, LLC
West Elevation - 09.26.07